

# Documentation

HiPath 8000

OpenStage 40

Quick Reference Guide



Communication for the open minded

Siemens Enterprise Communications  
[www.siemens.com/open](http://www.siemens.com/open)

**SIEMENS**

# Using Your Telephone

## Function Keys and Audio Keys

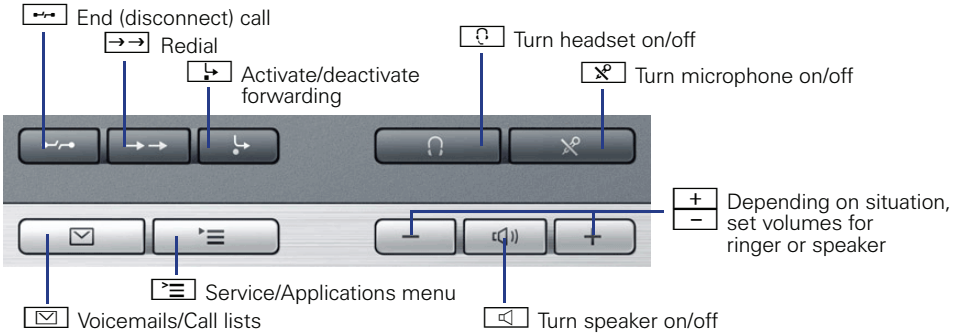

## 5-way navigator

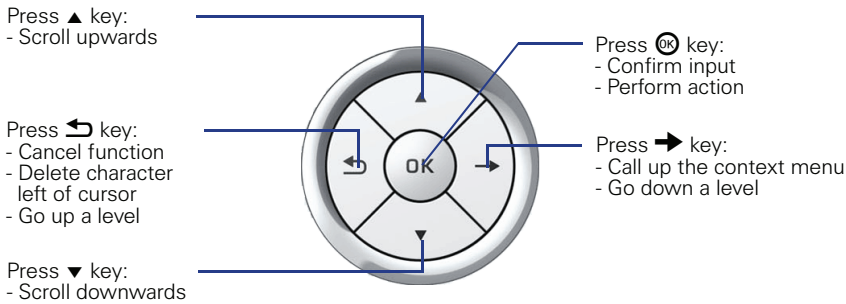

## Programmable sensor keys on the display



## Display

### Components

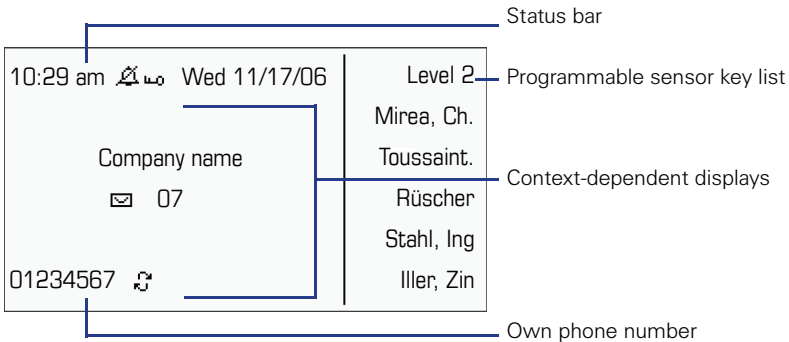



## Entering Phone Numbers and Text





### Keypad

In situations where text entry is possible, you can use the dial keys to enter text, punctuation and special characters. To do this, press the numerical keys repeatedly.

Extra asterisk and pound key functions:

Key	Function during text input	Function when held down
	Write special characters	Deactivate the ring tone.
	Switch between upper/lower case and digit entry.	Activate telephone lock.

# Important Operating Procedures

 Lift handset	 Enter text or number
 Replace handset	 Select entry
 Conduct call	 Open context menu
 Ring tone/call waiting tone	 Next step in procedure

## In Idle State

---

### Answering a call with the handset



### Answering a call in speakerphone mode



### Rejecting a call

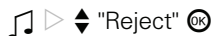

### Deflecting a call



### Dialing from the caller list

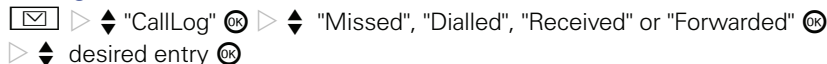

### Activating callback

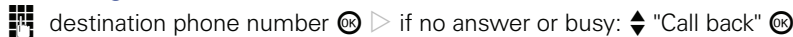



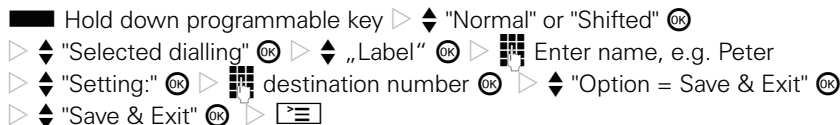

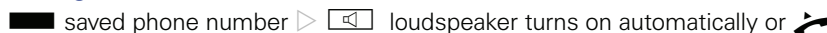

### Saving a phone number to a key





### Dialing a saved number



### Saving a function to a key

- Hold down programmable key ▷ ◆ "Normal" or "Shifted" 
- ▷ ◆ select function  (for functions with phone number: ▷ ◆ "Setting:" 
- ▷ enter the phone number) ▷ ◆ "Option = Save & Exit"  ▷ ◆ "Save & Exit"  ▷ 

### Redialing a number

-  "Repeat dialling" ▷ ◆ desired number  ▷ 

### Programming call forwarding

-  ▷ ◆ "Edit call forwarding"  ▷ ◆ "Destination" (e. g. under "All calls") 
- ▷ "Edit favourites"  ▷ ◆ "Destination 1"  ▷  phone number 
- ▷ Selected forwarding type, e.g. ◆ "All calls"  ▷  ▷ ◆ "On" 
- ▷ ◆ "Options = Save & Exit"  ▷ ◆ "Save & Exit"  ▷ 

### Turning call forwarding on/off for all calls

Requirement: Forwarding destination for "All calls" was programmed.









### During Calls with a Party A

#### Switching to speakerphone mode

Hold down  ▷  (US only:  ▷ )

#### Consultation

→ ▷ "Consultation"  ▷  phone number for party B  ▷  party B ▷ →  
▷  ▷  party A









#### Accepting call waiting

 call waiting tone ▷  "Accept"  ▷  party B ▷  party B ▷ →  
▷   "Disconnect & return"  ▷  party A

#### Deflect call on call waiting

 Call waiting tone ▷  "Deflect"  ▷  phone number for party B  ▷  party A

#### Start conference

→ ▷ "Consultation"  ▷  phone number for party B  ▷  party B ▷ →  
▷   "Conference"  ▷  party A and B







#### Start conference on call waiting

 call waiting tone ▷  "Accept"  ▷  party B ▷ → ▷  "Conference"   
▷  party A and B

#### Blind transfer to party B

→ ▷  "Consultation"  ▷  destination phone number  ▷ 

#### Transfer after consultation

→ ▷  "Consultation"  ▷  phone number for party B  ▷  party B ▷ 

Reference No.:  
A31003-S2000-U113-1-7619

## Communication for the open minded

**Siemens Enterprise Communications**  
[www.siemens.com/open](http://www.siemens.com/open)

© **Siemens Enterprise  
Communications GmbH & Co. KG**  
**Hofmannstr. 51,**  
**D-81359 München**

The information provided in this document contains merely general descriptions or characteristics of performance which in case of actual use do not always apply as described or which may change as a result of further development of the products. An obligation to provide the respective characteristics shall only exist if expressly agreed in the terms of contract. Subject to availability. Right of modification reserved. The trademarks used are owned by Siemens Enterprise Communications GmbH & Co. KG or their respective owners.